

MECHANICAL ENGINEERING

Machine Design

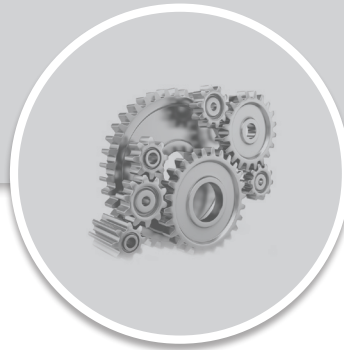

Comprehensive Theory
with Solved Examples and Practice Questions





MADE EASY Publications Pvt. Ltd.

Corporate Office: 44-A/4, Kalu Sarai (Near Hauz Khas Metro Station), New Delhi-110016 | **Ph. :** 9021300500

Email : infomep@madeeasy.in | **Web :** www.madeeasypublications.org

Machine Design

Copyright © by MADE EASY Publications Pvt. Ltd.
All rights are reserved. No part of this publication may be reproduced, stored in or introduced into a retrieval system, or transmitted in any form or by any means (electronic, mechanical, photo-copying, recording or otherwise), without the prior written permission of the above mentioned publisher of this book.

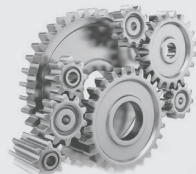

MADE EASY Publications Pvt. Ltd. has taken due care in collecting the data and providing the solutions, before publishing this book. In spite of this, if any inaccuracy or printing error occurs then **MADE EASY Publications Pvt. Ltd.** owes no responsibility. We will be grateful if you could point out any such error. Your suggestions will be appreciated.

EDITIONS

First Edition : 2015
Second Edition : 2016
Third Edition : 2017
Fourth Edition : 2018
Fifth Edition : 2019
Sixth Edition : 2020
Seventh Edition : 2021
Eighth Edition : 2022
Ninth Edition : 2023
Tenth Edition : 2024
Eleventh Edition : 2025

Twelveth Edition : 2026

CONTENTS

Machine Design

CHAPTER 1

Design Against Fluctuating Load..... 1-17

1.1	Introduction.....	1
1.2	Types of Stresses	1
1.3	Stress Concentration	2
1.4	Endurance Limit	4
1.5	Notch Sensitivity	5
1.6	Gerber Line/Soderberg Line/Goodman Line.....	6
1.7	Low & High Cycle Fatigue; Finite and Infinite Life problem.....	10
1.8	Linear cumulative Damage rule (Miner's rule).....	11
	<i>Objective Brain Teasers</i>	12
	<i>Conventional Brain Teasers</i>	15

CHAPTER 2

Bolted, Welded and Riveted Joints..... 18-49

2.1	Introduction.....	18
2.2	Bolted Joint	18
2.3	Welded Joints.....	23
2.4	Riveted Joint	31
	<i>Objective Brain Teasers</i>	37
	<i>Conventional Brain Teasers</i>	42

CHAPTER 3

Shaft and Key..... 50-69

3.1	Shaft.....	50
3.2	Design of solid Shaft on Strength Basis	51
3.3	Design of solid on Torsional Rigidity Basis.....	52
3.4	Design of Hollow Shaft on Strength Basis	53

3.5	Design of Hollow Shaft on Torsional Rigidity Basis	55
-----	--	----

3.6	Keys	57
-----	------------	----

	<i>Objective Brain Teasers</i>	63
--	--------------------------------------	----

	<i>Conventional Brain Teasers</i>	67
--	---	----

CHAPTER 4

Theory of Springs..... 70-82

4.1	Introduction.....	70
-----	-------------------	----

4.2	Types of Springs	70
-----	------------------------	----

4.3	Springs in combination	74
-----	------------------------------	----

4.4	Leaf Spring	75
-----	-------------------	----

	<i>Objective Brain Teasers</i>	77
--	--------------------------------------	----

	<i>Conventional Brain Teasers</i>	80
--	---	----

CHAPTER 5

Clutches..... 83-99

5.1	Introduction.....	83
-----	-------------------	----

5.2	Location of a clutch.....	83
-----	---------------------------	----

5.3	Types of Clutches.....	84
-----	------------------------	----

5.4	Principle of Friction Clutches.....	84
-----	-------------------------------------	----

5.5	Cone Clutches	88
-----	---------------------	----

5.6	Centrifugal Clutch.....	90
-----	-------------------------	----

	<i>Objective Brain Teasers</i>	92
--	--------------------------------------	----

	<i>Conventional Brain Teasers</i>	97
--	---	----

CHAPTER 6

Brakes..... 100-124

6.1	Introduction.....	100
-----	-------------------	-----

6.2	Materials for Brake Lining	100
-----	----------------------------------	-----

6.3	Types of Brakes	101
6.4	Block or Shoe Brake.....	101
6.5	Band Brake.....	105
6.6	Band and Block Brake.....	109
6.7	Internal Expanding Shoe Brake.....	111
	<i>Objective Brain Teasers</i>	114
	<i>Conventional Brain Teasers</i>	117

CHAPTER 7

Gears 125-140

7.1	Gears.....	125
7.2	Spur Gears	125
	<i>Objective Brain Teasers</i>	130
	<i>Conventional Brain Teasers</i>	134

CHAPTER 8

Bearings..... 141-161

8.1	Introduction.....	141
8.2	Classification of Bearing	141
8.3	Types of Rolling Contact Bearing	142
8.4	Selection of rolling contact bearing.....	144
8.5	Sliding Contact bearing.....	146
	<i>Objective Brain Teasers</i>	151
	<i>Conventional Brain Teasers</i>	156



Design Against Fluctuating Load

1.1 INTRODUCTION

The mechanism by which a requirement is converted into meaningful and functional plan is called a design. The design is an innovative, iterative and decision making process. This book deals with analysis and design of machine elements.

Purpose and scope of design

- It presents a body of knowledge that will be useful in components design for performance, strength and durability.
- It provides treatment of design to meet strength requirements of members and other aspects of design involving prediction of displacement, buckling of a component.

1.1.1 Design against fluctuating load

In many engineering application a machine component is subjected to a fluctuating load due to which it fails at stress levels subsequently lower than the yield strength of material.

The phenomenon of progressive fracture due to repeated loading is called as fatigue and it is observed that fatigue failure begins with a crack at some point inside the component. These cracks are not visible till they reach the surface of component which results in sudden and total failure of component.

1.2 TYPES OF STRESSES

1.2.1 Fluctuating Stress

The stresses which vary from a minimum value to a maximum value of the same nature (i.e. tensile or compressive) are called fluctuating stresses.

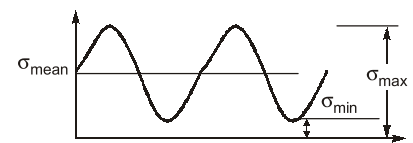

Figure: Fluctuating stress cycle

1.2.2 Repeated Stress

Stress variation is such that the minimum stress is zero, mean and amplitude stress have the same value for repeated loading.

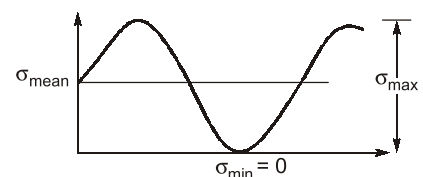

Figure: Repeated stress cycle

1.2.3 Cyclic Stress

The stresses which vary from one value of compressive to the same value of tensile or vice versa, are known as completely reversed or cyclic stresses.

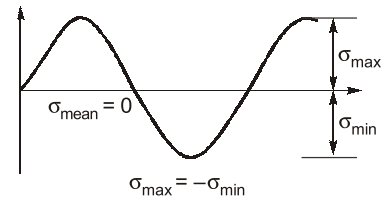

Figure: Completely reversed or cyclic stress

1.2.4 Alternating Stress

The stresses which vary from a minimum value to a maximum value of the opposite nature (i.e. from a certain minimum compressive to a certain maximum tensile or from a minimum tensile to a maximum compressive) are called alternating stresses.

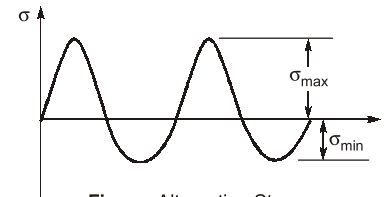

Figure: Alternating Stress

1.2.5 Fluctuating Stress Cycle

$$\text{Mean stress, } \sigma_{\text{mean}} \text{ or } \sigma_{\text{avg}} = \frac{\sigma_{\text{max}} + \sigma_{\text{min}}}{2}$$

$$\text{Stress amplitude, } \sigma_a = \frac{\sigma_{\text{max}} - \sigma_{\text{min}}}{2}$$

$$\text{Range of stress, } \sigma_R = \sigma_{\text{max}} - \sigma_{\text{min}}$$

$$\text{Stress ratio} = \frac{\sigma_{\text{min}}}{\sigma_{\text{max}}}$$

$$\text{Amplitude ratio} = \frac{\sigma_a}{\sigma_{\text{mean}}}$$

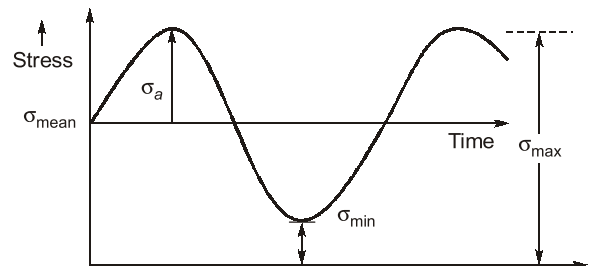

Figure: Fluctuating Stress Cycle

1.3 STRESS CONCENTRATION

Stress concentration is defined as the localization of high stresses due to the irregularities present in the component and abrupt changes of the cross-section. In order to define stress concentration let us consider an example of rectangular cross section plate of thickness t with a circular hole of diameter d at centre subjected to tensile stress'

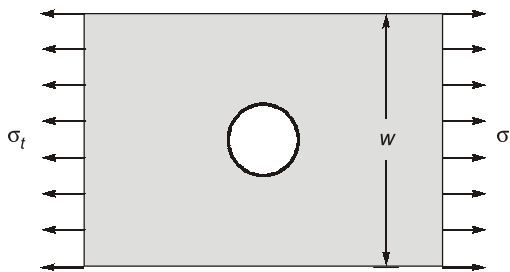

Figure: Plate with circular hole

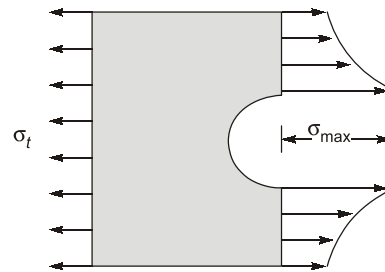

Figure: Stress distribution around circular hole

By using photoelastic technique it is observed that the distribution of stresses near the hole are greater than the nominal stress (σ_o), where nominal stress,

$$\sigma_o = \frac{\sigma_t w t}{(w - d)t} = \frac{\sigma_t w}{(w - d)}$$

The main causes of stress concentration are:

- (a) Variation in properties of material due to impurities, cavities etc.
- (b) Abrupt changes in section in order to mount gears, sprockets etc.
- (c) Discontinuities in component due to certain machine features such as oil holes, keyways etc.

So in order to consider the effect of stress concentration, a factor called stress concentration factor is used.

1.3.1 Stress Concentration Factor

Geometric stress concentration factors can be used to estimate the stress amplification in the vicinity of a geometric discontinuity.

- k_t (theoretical stress concentration factor) is used to relate the maximum stress at the discontinuity to the nominal stress.
- k_{ts} is used for shear stresses
- k_t is based on the geometry of the discontinuity

$$k_t = \frac{\text{Highest value of actual stress near discontinuity}}{\text{Nominal stress obtained by elementary equations for minimum cross-section}}$$

or

$$k_t = \frac{\sigma_{\max.}}{\sigma_0} = \frac{\tau_{\max.}}{\tau_0}$$

NOTE : Stress concentration in a machine component of ductile materials not so harmful as it is in brittle material because in ductile material local yielding may distribute stress concentration.

1.3.2 Stress concentration factor for different geometry

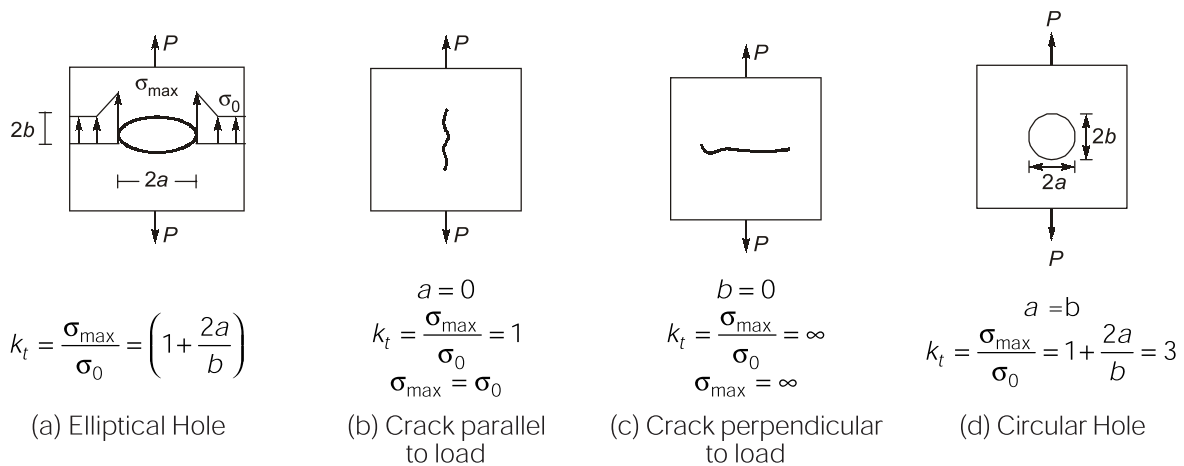

Figure: Stress concentration factor for different geometry

1.3.3 Methods to find theoretical stress concentration factor (k_t)

Experimental Method	Mathematical Method
<ul style="list-style-type: none"> • Photo-elasticity method • Brittle-coating method • Strain gauge 	<ul style="list-style-type: none"> • Finite element method

1.3.4 Methods to reduce stress concentration

- For designing purpose, if there is some sudden change in stress line, smooth transition called fillet is used due to this stress line have gradual change, hence k_t value reduces.
- For reducing k_t magnitude small diameter holes are made near bigger diameter hole for converting sudden change of stress flow lines into gradual change.

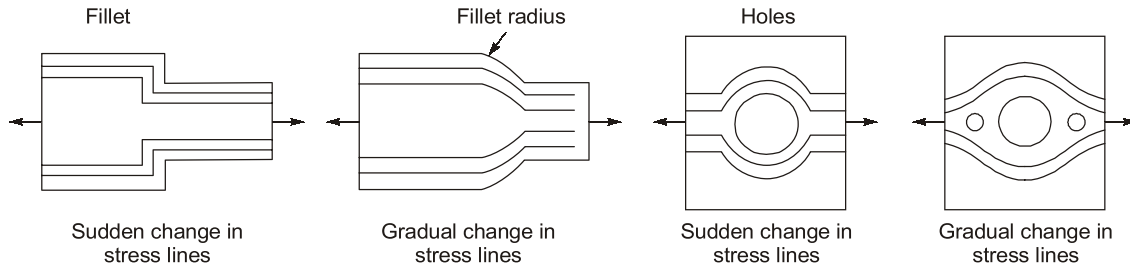

Figure: Stress concentration reduction methods

1.4 ENDURANCE LIMIT

The endurance limit of standard specimen is defined as maximum amplitude of completely reversed stress that a standard specimen can sustain for infinite number of cycles without causing fatigue failure. As the fatigue test cannot be conducted for infinite number of cycles so 10^6 number of cycles is considered as infinite number of cycles in order to define endurance limit.

1.4.1 Methods to increase endurance strength

Endurance strength (Fatigue strength) can be improved by including compressive pre-load and due to this stress amplitude decreases.

1. Hammering
2. Shot peening
3. Burnishing
4. Cold rolling

1.4.2 Modified Endurance Limit (σ_e')

The specimen used in laboratory to determine endurance limit is prepared very carefully and tested under closely controlled conditions. However, component material, manufacturing method, shape, size, residual stress also influence fatigue. So to account for these effect various modifying factors are used.

1. Size factor, (k_{size})
2. Load factor, (k_{load})
3. Surface finish factor, (k_{sf})
4. Reliability factor, ($k_{reliability}$)
5. Temperature factor, (k_{temp})
6. Modification factor, (k_{modi})
7. Miscellaneous, ($k_{miscellaneous}$)

If designer considers effect of all these factors, endurance strength value can be determined by given equation

$$\sigma_e' = k_{sf} k_{temp} k_{load} k_{size} k_{reliability} k_{modi} k_{miscellaneous} \sigma_e$$

1.4.2.1 Surface finish factor

Endurance strength is sensitive to condition of surface because maximum stress occurs here in bending and torsion. So we can say that as surface finish increases endurance strength increases.

$$k_{SF} = a(\sigma_{ut})^b$$

where value of a , b is given in table below.

Surface Finish	a	b
Ground	1.58	-0.085
Machined	4.51	-0.265
Hut Rolled	57.7	-0.718
Forged	272	-0.995

NOTE: For a polished specimen $K_{SF} = 1$

1.4.2.2 Size Factor

The endurance strength decreases with increasing member size. This is owing to probability that a larger part has a defect somewhere in the member.

1.4.2.3 Load Factor

The endurance limit in axial loading is lower than the bending load because in bending it is only the outer region near surface which is subjected to maximum stress. Whereas in axial loading whole cross-section is uniformly stressed. So there is more likelihood of a micro crack being present in high stress region of axial load as compared to bending load. For axial loading $k_L = 0.8 \sigma_e$

1.4.2.4 Reliability Factor

Reliability factor depends on component life of serving. Greater the surviving time more the reliability and lower the reliability factor.

As load increases, then the reliability decreases. For the reliability of 50 percent, reliability factor will be 1.

$$k_{50\%} = 1$$

1.4.2.5 Temperature Factor

The effect of temperature vary with material in most cases. For steel a temperature factor k_T can be approximated at a moderately high temperature by formula.

$$k_T = 1, T \leq 450^\circ\text{C}$$

$$k_T = 1 - 0.0058(T - 450); \quad 450^\circ\text{C} \leq T \leq 550^\circ\text{C}$$

1.4.2.6 Modification Factor

$$k_{\text{modi}} = \frac{1}{k_f}$$

Modification factor is used to compensate effect of fatigue stress concentration factor k_f .

where,

$$k_f = \frac{\text{Endurance limit of notched free specimen}}{\text{Endurance limit of notched specimen}}$$

1.5 NOTCH SENSITIVITY

As studied earlier, the stress concentration is very significant factor in failure by fatigue. For dynamic loading the theoretical stress concentration factor k_t needs to be modified on the basis of notch sensitivity of the material. The notch is generic term and it can be hole, a groove or a fillet. The test shows that k_f is often equal to or less than k_t due to internal irregularities in material structure. An extreme case in point is grey cast iron. The two stress factor are related by notch sensitivity q .

$$\text{Gerber Criteria, } \frac{\sigma_a}{\sigma_e} \times \text{FOS} + \left(\frac{\sigma_m}{\sigma_{ut}} \right)^2 = 1$$

$$\Rightarrow 0.2857 \text{ FOS} + 0.08163 \text{ FOS}^2 = 1$$

$$\text{FOS} = 2.163167$$

$$\text{Stress ratio, } \frac{\sigma_{\min}}{\sigma_{\max}} = \frac{100}{300} = 0.333$$

$$\text{Amplitude ratio, } \frac{\sigma_a}{\sigma_m} = \frac{100}{200} = 0.5$$

$$\text{Range of stress, } \sigma_{\max} - \sigma_{\min} = 300 - 100 = 200 \text{ MPa}$$

EXAMPLE : 1.2

A machine component under fluctuating tensile stresses is considered to be safe if the average stress and stress amplitude satisfy the following inequality,

$$\frac{\sigma_{\text{avg}}}{360} + \frac{\sigma_{\text{amp}}}{210} \leq 1$$

The machine member is subjected to stress $[120 + P \sin(20t + 0.8)]$ MPa. For safe working of member, the minimum value of P is _____ MPa.

Solution:

Given:

$$\sigma = 120 + P \sin(20t + 0.8)$$

$$\sigma_{\max} = 120 + P \text{ (because max. value of sin ratio is 1)}$$

$$\sigma_{\min} = 120 - P \text{ (because min. value of sin ratio is -1)}$$

$$\sigma_{\text{mean}}, \sigma_m = \frac{120 + P + 120 - P}{2} = 120 \text{ MPa}$$

$$\sigma_{\text{amplitude}}, \sigma_a = \frac{120 + P - 120 + P}{2} = P \text{ MPa}$$

$$\therefore \frac{120}{360} + \frac{P}{210} = 1$$

$$\Rightarrow P = 140 \text{ MPa}$$

1.7 LOW & HIGH CYCLE FATIGUE; FINITE AND INFINITE LIFE PROBLEM

Figure: SN curve

EXAMPLE : 1.3

A cylindrical shaft is subjected to an alternating stress of 100 MPa. Fatigue strength to sustain 100 cycles is 490 MPa. If the corrected endurance strength is 70 MPa, then the estimated shaft life will be ____ cycles.

Solution:

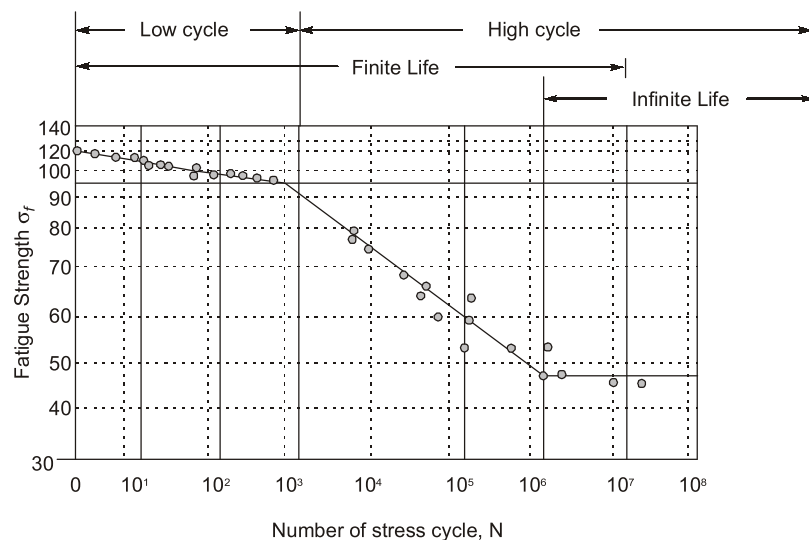
It is a finite life problem. The line AB is the failure line, where A [$3, \log_{10}(0.9\sigma_{ut})$] But here it will be A [$3, \log_{10}(490)$] and B [$6, \log_{10}(70)$] Therefore, F [$\log_{10} N, \log_{10}(100)$] we have to find N

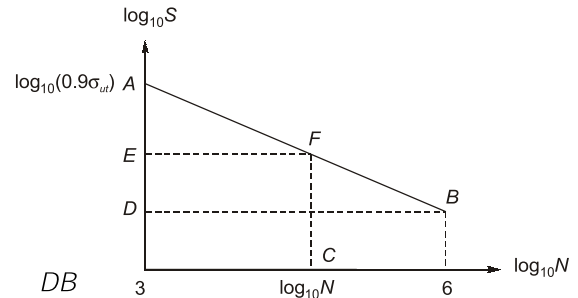

$$\frac{EF}{AE} = \frac{DB}{AD}$$

$$\text{or } \frac{\log_{10} N - 3}{\log_{10} 490 - \log_{10} 100} = \frac{6 - 3}{\log_{10} 490 - \log_{10} 70}$$

$$\text{or } N = 281914 \text{ cycles.}$$

■ ■ ■ ■

**OBJECTIVE
BRAIN TEASERS**

Q.1 Equation of Goodman line is given by

(a) $\frac{\sigma_m}{S_{yt}} + \frac{\sigma_a}{S_e} = 1$

(b) $\frac{S_{yt}}{\sigma_m} + \frac{\sigma_a}{S_e} = 1$

(c) $\frac{\sigma_m}{S_{ut}} + \frac{\sigma_a}{S_e} = 1$

(d) $\frac{\sigma_m}{S_{ut}} + \frac{S_e}{\sigma_a} = 1$

Q.2 Ratio of increase of actual stress over nominal stress to increase of theoretical stress over nominal stress is called

- (a) Endurance limit
(b) Fatigue strength
(c) Mean fluctuating stress
(d) Notch sensitivity

Q.3 Stress concentration factors are used for components made of brittle material subjected to

- (a) Static load (b) Fluctuating load
(c) Both (a) & (b) (d) None of these

Q.4 Theoretical stress concentration factor at the edge of hole is given by

(a) $1 + \frac{a}{b}$

(b) $1 + \frac{b}{a}$

(c) $1 + 2\left(\frac{b}{a}\right)$

(d) $1 + 2\left(\frac{a}{b}\right)$

where, a = Semi-axis of ellipse perpendicular to direction of load,

b = Semi-axis of ellipse in direction of load.

Q.5 Stress concentration is due to

- (a) Irregularities present in the component
(b) Abrupt change of concentration
(c) Both (a) and (b)
(d) None of these

Q.6 Reduction of stress concentration can be achieved by

- (a) Additional notches in member under tension
(b) Addition holes in member under tension
(c) Both (a) and (b)
(d) None of these

Q.7 A link is under a pull which lies on one of the faces as shown in the figure below. The magnitude of maximum compressive stress in the link would be

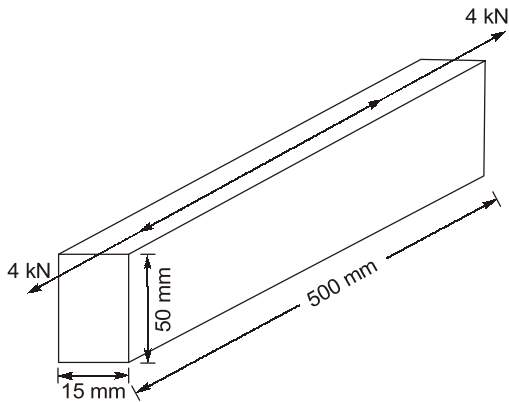

- (a) 21.3 N/mm² (b) 16.0 N/mm²
(c) 10.7 N/mm² (d) Zero

Q.8 A loaded semi-infinite flat plate is having an elliptical hole $\left(\frac{A}{B} = 2\right)$ in the middle as shown in the figure below. The stress concentration factor for the plate is

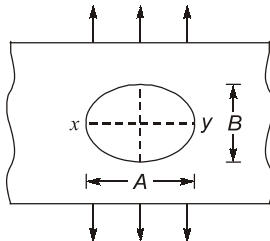

- (a) 1 (b) 3
(c) 5 (d) 7

Q.9 A shaft is subjected to maximum and minimum bending moment of 150 kNm and -50 kNm. $S_{ut} = 600$ MPa, $S_{yt} = 400$ MPa and corrected endurance limit is 375 MPa, then minimum safe radius of shaft using soderberg criteria [FOS = 2] is

(a) 200 mm (b) 158 mm
(c) 100 mm (d) 192 mm

Q.10 Statement (I): Endurance limit in axial loading is lower than that in reverse bending.

Statement (II): Possibility of microcrack being present under high stress in axial loading is higher than that of reverse bending.

- (a) Both Statement (I) and Statement (II) are true and Statement (II) is the correct explanation of Statement (I).

- (b) Both Statement (I) and Statement (II) are true but Statement (II) is not a correct explanation of Statement (I).
(c) Statement (I) is true but Statement (II) is false.
(d) Statement (I) is false but Statement (II) is true.

Q.11 A cantilever beam of length 1 m undergoes fluctuating load of 5 kN to 10 kN at it's free end. The theoretical stress concentration factor of beams is 2.5 and notch sensitivity is 0.4. The properties of ductile material of beam are $\sigma_e = 150$ MPa, $\sigma_{yt} = 250$ MPa, $\sigma_{ut} = 550$ MPa and section modulus of beam is 5×10^4 mm³.

The FOS of beam is _____ (Using Soderberg theory of failure)

- (a) 0.88 (b) 1.133
(c) 1.071 (d) 1.65

Q.12 A component of a machine in subjected to biaxial state of stress as shown by stress tensor.

$$[\sigma]_{2D} = \begin{bmatrix} 100 & 20 \\ 20 & 50 \end{bmatrix} \text{MPa}$$

The yield strength of the material is same is tension and compression and is equal to 400 MPa. The ratio of factor of safety determined by using maximum shear stress theory and maximum distortion energy theory is

- (a) 0.87 (b) 1.15
(c) 0.72 (d) 1.39

Q.13 A material is fully sensitive to notches, then the fatigue stress concentration factor is

- (a) $k_f = k_t + 1$ (b) $k_f = k_t - 1$
(c) $k_f = k_t$ (d) $k_f = 2k_t$



ANSWER KEY

1. (c) 2. (d) 3. (c) 4. (d) 5. (c)
6. (c) 7. (c) 8. (c) 9. (c) 10. (a)
11. (a) 12. (a) 13. (c)

HINTS & EXPLANATIONS

3. (c)

The effect of stress concentration is more severe in case of brittle materials due to their inability of plastic deformation. Stress concentration factors are used for components made of brittle materials subjected to both static as well as fluctuating load.

7. (c)

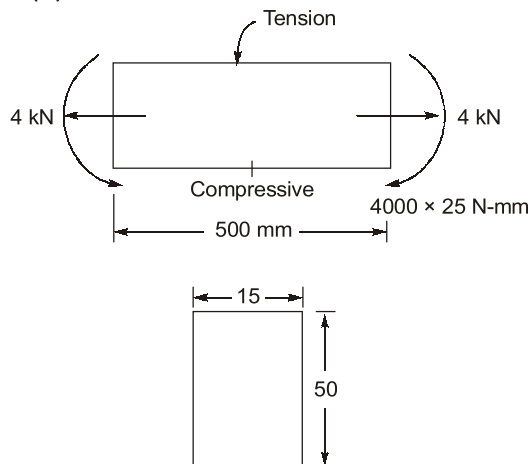

Equivalent figure,
Bending stress,

$$\sigma_b = \frac{M}{I} y = \frac{4000 \times 25}{\frac{1}{12} \times 15 \times (50)^3} \times 25 = 16 \text{ MPa}$$

Tensile stress,

$$\sigma_t = \frac{F}{A} = \frac{4000 \text{ N}}{15 \times 50 \text{ mm}^2} = 5.33 \text{ MPa}$$

Maximum compressive stress

$$= \sigma_b - \sigma_t = 16 - 5.33 \\ = 10.67 \text{ MPa}$$

8. (c)

$$k_T = 1 + \frac{2A}{B} = 1 + 2 \times 2 = 5$$

9. (c)

$$(M_b)_m = \frac{150 + (-50)}{2} = 50 \text{ kNm}$$

$$(M_b)_v = \frac{150 - (-50)}{2} = 100 \text{ kNm}$$

$$(\sigma_b)_m = \frac{32 \times 50 \times 10^6}{\pi d^3} \text{ MPa}$$

$$(\sigma_b)_v = \frac{32 \times 100 \times 10^6}{\pi d^3}$$

Soderberg line equation,

$$\frac{\sigma_m}{S_{yt}} + k_f \frac{\sigma_v}{S_e} = \frac{1}{N}$$

$$\frac{32 \times 50 \times 10^6}{\pi d^3 \times 400} + 1 \times \frac{32 \times 100 \times 10^6}{\pi d^3 \times 375} = \frac{1}{2}$$

$$2 \times (1273239.545 + 2716244.362) = d^3$$

$$d^3 = 7978967.814$$

$$d = 199.82 \approx 200 \text{ mm}$$

$$\pi = \frac{d}{2} = 100 \text{ mm}$$

10. (a)

In axial loading, the entire cross-section is uniformly stressed to maximum value. In the reversed bending, the bending stress is zero at the centre of cross-section and it is maximum at outer fibres. So less area is subjected to high stress and also possibility of micro cracks or cracks reduces than axial loading where whole area is subjected to high stress.

11. (a)

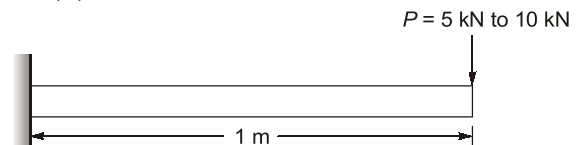

$$P_a = \frac{P_{\max} - P_{\min}}{2} = \frac{10 - 5}{2} = 2.5 \text{ kN}$$

$$P_m = \frac{P_{\max} + P_{\min}}{2} = \frac{10 + 5}{2} = 7.5 \text{ kN}$$

$$\sigma_a = \frac{M_a}{z} = \frac{2.5 \times 1 \times 10^6}{5 \times 10^4} = 50 \text{ MPa}$$

Similarly $\sigma_m = 150 \text{ MPa}$

As per soderberg criteria of failure,

$$\frac{1}{FOS} = \frac{\sigma_a \times k_f}{\sigma_e} + \frac{\sigma_m}{\sigma_{yt}}$$

(k_t is not required for ductile material)

$$k_f = 1 + q(k_t - 1)$$

$$= 1 + 0.4(2.5 - 1) = 1.6$$

$$\frac{1}{FOS} = \frac{1.6 \times 50}{150} + \frac{150}{250}$$

$$\Rightarrow FOS = 0.8823$$

(Hence material will fail after certain no. of cycles)

12. (a)

Given: $S_{yt} = S_{yc} = 400$ MPa

$$\sigma = \begin{bmatrix} 100 & 20 \\ 20 & 50 \end{bmatrix}$$

$\sigma_x = 100$, $\sigma_y = 50$, $\tau_{xy} = 20$

Principal stresses, σ_1, σ_2

$$\sigma_{1,2} = \frac{1}{2} \left[(\sigma_x + \sigma_y) \pm \sqrt{(\sigma_x - \sigma_y)^2 + 4\tau_{xy}^2} \right]$$

$$\sigma_{1,2} = \frac{1}{2} \left[150 \pm \sqrt{50^2 + 4 \times 20^2} \right] = \frac{1}{2} [150 \pm 64.03]$$

$$\sigma_{1,2} = 107.015 \text{ MPa}, 42.984 \text{ MPa}$$

From maximum shear stress theory,

$$\text{Max } [(\sigma_1 - \sigma_2), (\sigma_1), (\sigma_2)] \leq \frac{S_{yt}}{N_1}$$

$$\Rightarrow 107.015 \leq \frac{400}{N_1}$$

$$N_1 \leq 3.737$$

From maximum distortion energy theory,

$$\sigma_1^2 + \sigma_2^2 - \sigma_1\sigma_2 \leq \left(\frac{S_{yt}}{N_2} \right)^2$$

$$\Rightarrow 8699.9 \leq \left(\frac{400}{N_2} \right)^2$$

$$\Rightarrow N_2 = 4.288$$

The ratio of factor of safety = $\frac{N_1}{N_2} = 0.87$

13. (c)

When a material is fully sensitive to notches

$$\Rightarrow q = 1$$

So, $k_f = 1 + q(k_t - 1) = 1 + (k_t - 1)$

$$k_f = k_t$$



CONVENTIONAL BRAIN TEASERS

Q.1 The section of a steel shaft is shown in figure. The shaft is machined by a turning process. The shaft is machined by a turning process. The section at XX is subjected to a constant bending moment of 500 kN-m. The shaft material has ultimate tensile strength of 500 MN/m², yield point 350 MPa and endurance limit in bending is 210 MN/m². The notch sensitivity factor can be taken as 0.8. The values of surface finish factor, size factor and reliability factor are 0.79, 0.75 and 0.897 respectively. The theoretical stress concentration factor may be interpolated from following tabulated values:

$\frac{r_f}{d}$	0.025	0.05	0.1
k_t	2.6	2.05	1.66

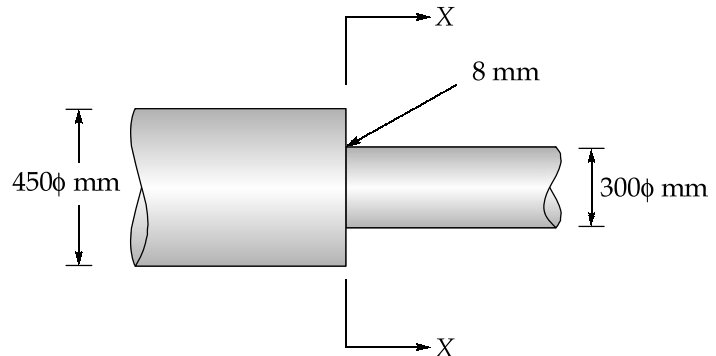

where r_f is the fillet radius and 'd' is the shaft diameter. Determine the life of the shaft.

Solution:

Given : $M_b = 500$ kNm, $S_{ut} = 500$ MN/m², $S_{yt} = 350$ MN/m², $S'_e = 210$ MN/m², $q = 0.8$, $k_a = 0.79$, $k_b = 0.75$,
 $k_c = 0.897$

Since,
$$\frac{r_f}{d} = \frac{8}{300} = 0.02667$$

∴ From table,
$$k_t = 2.05 + \frac{2.6 - 2.05}{0.05 - 0.025}(0.05 - 0.02667)$$

$$k_t = 2.563, q = 0.8$$

$$k_f = 1 + q(k_t - 1)$$

$$= 1 + 0.8(2.563 - 1) = 2.25$$

∴
$$k_d = \frac{1}{k_f} = \frac{1}{2.25} = 0.444$$

Corrected endurance limit,
$$S_e = k_a k_b k_c k_d S'_e = 0.79 \times 0.75 \times 0.897 \times 0.444 \times 210$$

$$= 49.5 \text{ N/mm}^2$$

$$M_b = 500 \text{ kNm}$$

$$\sigma_b = \frac{32 \times M_b}{\pi d^3} = \frac{32 \times 500 \times 10^6}{\pi (300)^3} = 188.63 \text{ N/mm}^2$$

$$0.9S_{ut} = 0.9 \times 500 = 450 \text{ N/mm}^2$$

$$\log_{10}(0.9S_{ut}) = \log_{10}(450) = 2.6532$$

$$\log_{10}(S_e) = \log_{10}(49.5) = 1.695$$

$$\log_{10}(\sigma_b) = \log_{10}(188.63) = 2.2756$$

The S-N curve for the shaft is shown in figure below

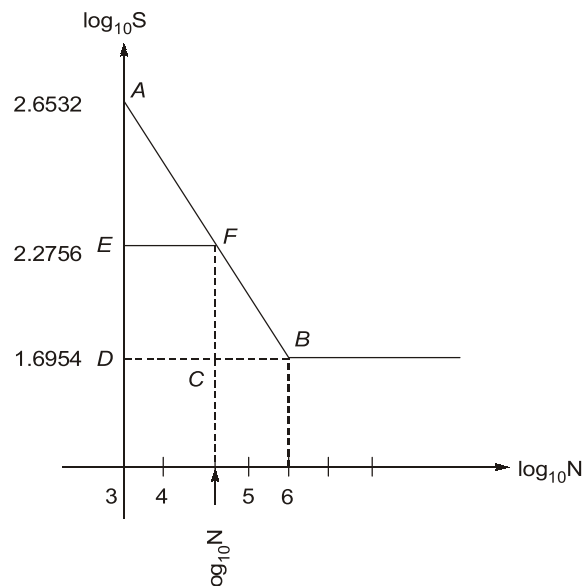

From figure,

$$\overline{EF} = \frac{\overline{DB} \times \overline{AE}}{\overline{AD}} = \frac{(6 - 3)(2.6532 - 2.2756)}{(2.6532 - 1.695)}$$